

In-Ceiling Dual Screen w / two aspect ratios One Housing Self-Supported Surfaces



Features:

- » Features two screen formats in one housing
- » Also available in 2.35:1 / 16:9 or other format combinations
- » Screens lower in same plane
- » Ceiling flush mount with automatic trap door
- » Choice of black or white mica finishes
- » Ribbed aluminum 3" roller with FRS™ (Fabric Relief Step)
- » Acoustical dampening for silent operation DDR™ (Dual Dampened Roller)
- » Includes dual channel IR remote control
- » Trim kit included
- » Standard 12" black leader for both screens
- » 5 year warranty

Unique to Vision X, the X2 Features a Dual Format, Dual Roller Design for Multiple Projection Applications



U.S. Patent No. 5,353,152

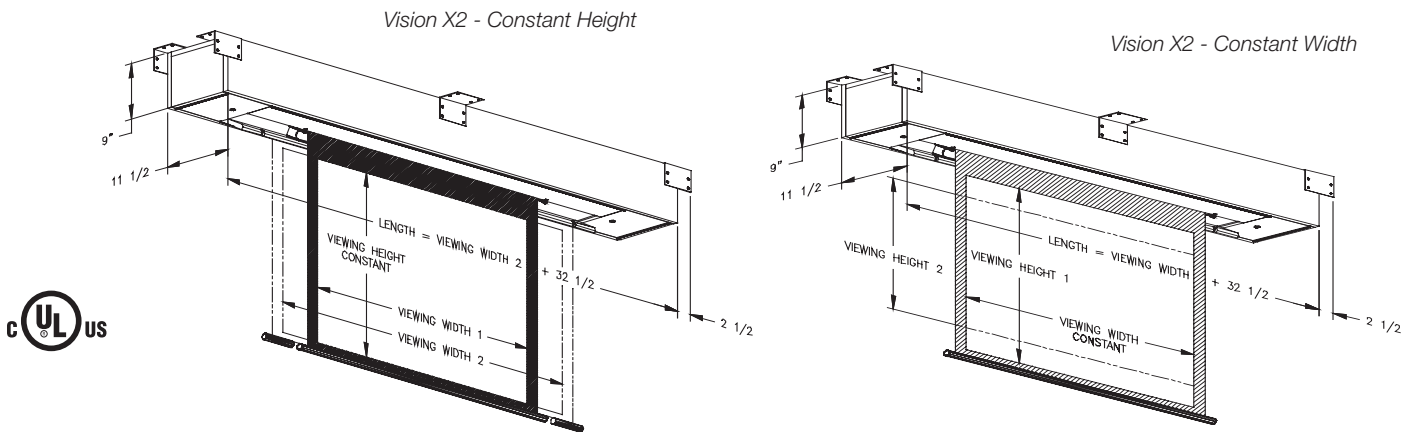

PART NUMBER + SURFACE OPTION + VOLTAGE						SURFACES				Shipping
Format	Diagonal	Viewing Area	Overall Dimension	Part Numbers	Housing Color Black: (B) White: (W) Custom: (C)	MSRP (\$)	Dealer Net (\$)	MSRP (\$)	Dealer Net (\$)	
EXAMPLE: X2045-105 PRB 1						1 = 110V OR 2 = 220V	Vu-Flex Pro: (PR)		SoundScreen:(SS) GreyDove SoundScreen: (GS)	
Constant Height										
2.35:1	115"	45" x 105.75"	138.50"	X2045-105XXX	B/W/C	CONTACT YOUR ACCOUNT MANAGER FOR PRICES				240 lbs
16:9	92"	45" x 80"	138.50"	X2045-105XXX	B/W/C					260 lbs
2.35:1	129"	50.50" x 118.75"	151.25"	X2050-118XXX	B/W/C					270 lbs
16:9	103"	50.50" x 89.75"	159.50"	X2054-127XXX	B/W/C					295 lbs
2.35:1	138"	54" x 127"	173.50"	X2060-141XXX	B/W/C					
Constant Width										
16:9	92"	45" x 80"	112.50"	X2045-080XXX	B/W/C	CONTACT YOUR ACCOUNT MANAGER FOR PRICES				195 lbs
2.35:1	87"	34" x 80"	122.25"	X2050-089XXX	B/W/C					210 lbs
16:9	103"	50.50" x 89.75"	128.50"	X2054-096XXX	B/W/C					220 lbs
2.35:1	98"	38.25" x 89.75"	139.50"	X2060-107XXX	B/W/C					240 lbs
16:9	110"	54" x 96"								
2.35:1	105"	41" x 96"								

All measurements are nominal

Custom sizes and formats are available upon request

SoundScreen liner not available



For assistance on selecting the proper Vision X product, contact a Vutec Account Manager at (954) 545-9000 Prices subject to change without prior notice

Learn more at www.visionxscreen.com