

Heavy Duty Motorized Rising Arm Screen Self-Supported Surfaces

VISION XR HD

Features:

- » System is mounted in black or white mica cabinet
- » Automatic trap door up to certain sizes
- » Includes Vutec's Vu-Flex Pro internally-tensioned Surface
- » Available from 184" to 300" diagonal
- » Custom cabinetry finishes are available at an additional charge
- » Includes your choice of IR or RF remote or low voltage relay control
- » Requires custom consultation and sign-off
- » 5 year warranty

The Vision XR Motorized Rising Arm Screen is a Patented Self-Contained Screen System in Sizes up to 300" D



U.S. Patent No. 6,191,886

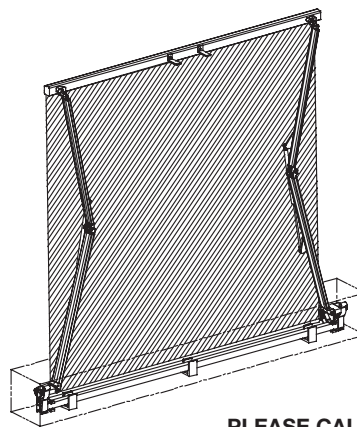
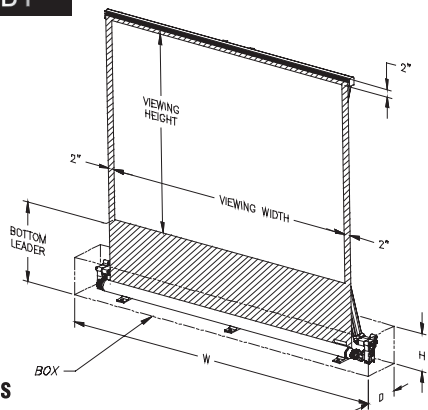

PLEASE CALL FOR FINAL DIMENSIONS & DRAWING

PART NUMBER + LEADER LIMIT + VOLTAGE							SURFACE		Shipping
Diagonal	Viewing Area	Part Numbers	Approximate Leader Limit	Borders (each)	Base Boards Dimensions (L x W)	Open Total Height	MSRP (\$)	Dealer Net (\$)	
EXAMPLE: XR120-160PR <u>20</u> <u>1</u>							Vu-Flex Pro: (PR)		
							1 = 110V OR 2 = 220V		
4:3 Standard Format									
200"	120" x 160"	XR120-160PRXXX	20"	2"	178" x 24"	143"	CONTACT YOUR ACCOUNT MANAGER FOR PRICES		780 lbs.
200"	120" x 160"	XR120-160PRXXX	52"	2"	220" x 24"	174"			1600 lbs.
240"	144" x 192"	XR144-192PRXXX	28"	2"	220" x 24"	174"			1600 lbs.
240"	144" x 192"	XR144-192PRXXX	49"	6"	240" x 24"	195"			1600 lbs.
280"	168" x 224"	XR168-224PRXXX	25"	2"	246" x 24"	195"			1600 lbs.
300"	180" x 240"	XR180-240PRXXX	18"	2"	261" x 24"	203"			1600 lbs.
16:9 HDTV Format									
184"	90" x 160"	XR090-160PRXXX	46"	9"	200" x 14"	138.50"	CONTACT YOUR ACCOUNT MANAGER FOR PRICES		850 lbs.
200"	98" x 174"	XR098-174PRXXX	38"	2"	200" x 14"	138.50"			850 lbs.
220"	108" x 192"	XR108-192PRXXX	64"	2"	220" x 24"	174"			1600 lbs.
240"	118" x 210"	XR118-210PRXXX	54"	2"	234" x 24"	174"			1600 lbs.
275"	135" x 240"	XR135-240PRXXX	58"	2"	230" x 24"	176"			1600 lbs.
280"	137" x 244"	XR137-244PRXXX	56"	2"	266" x 24"	195"			1600 lbs.
16:10 HDTV Format									
189"	100" x 160"	XR100-160PRXXX	36"	9"	200" x 14"	138.50"	CONTACT YOUR ACCOUNT MANAGER FOR PRICES		800 lbs.
205"	109" x 174"	XR109-174PRXXX	27"	2"	200" x 14"	138.50"			1600 lbs.
226"	120" x 192"	XR120-192PRXXX	52"	2"	220" x 24"	174"			1600 lbs.
248"	131" x 210"	XR131-210PRXXX	41"	2"	234" x 24"	174"			1600 lbs.
288"	152" x 244"	XR152-244PRXXX	56"	2"	266" x 24"	195"			1600 lbs.

All measurements are nominal

Custom sizes and formats are available upon request

Box H x W x D varies depending on screen size. Please consult with Vutec for details.



For assistance on selecting the proper Vision X product, contact a Vutec Account Manager at (954) 545-9000 Prices subject to change without prior notice

Learn more at www.visionxscreen.com